

PD Series

Instruction, Operating & Maintenance Manual



PD Series Gas Charged Dampeners
Well Service, Drilling, Slurry & Industrial Service



www.performancepulsation.com | sales@performancepulsation.com
3309 Essex Dr. Suite 200, Richardson, Texas 75082 | Phone: 972.699.8600 | Fax: 972.699.8602

2018 All Rights Reserved | Rev 6.22.2018

This manual describes operating practices and maintenance procedures applicable to PD Series Pulsation Dampeners manufactured by Performance Pulsation Control, Inc. The information contained herein reflects recommendations based on industry best practices and recognized safety protocols. Use of the information and procedures contained in this manual is voluntary and is to be implemented at the sole discretion of the user. The user is at all times responsible for operating and maintaining pulsation dampeners in a manner that is safe, conforms to the owner's established business practices, and is in conformance with applicable regulations.

NOTE: Please read all instructions carefully before proceeding with the installation, operation, and charging of this equipment. Contact Performance Pulsation Control for assistance or questions concerning the information in this manual.

MATERIALS NEEDED:

- API Seal Ring
- Grease Lubricant for Seal Ring
- Torque Wrench - Suitable for standard piping installation

INTRODUCTION:

Mount the dampener as close as possible to the pump for maximum effectiveness, installing the dampener within a length not to exceed 10 times the connecting pipe diameter. Installing the unit in a vertical orientation such that the fluid flows toward the bottom opening of the dampener to provide the greatest performance is recommended.

 **WARNING**

Do not pre-charge the dampener until it has been securely mounted in place. Use only nitrogen gas when pre-charging!

INSTALLATION INSTRUCTIONS

1. Thoroughly clean the mounting flange faces and check that the API ring grooves have uniform sealing surfaces.
2. Ensure the new API ring is clean and lightly coated with lubricant before installing in the mounting flange ring groove.
3. Place the API ring into the groove on the mounting surface of the pipe system.
4. Ensure the cover plate on the dampener is firmly attached.

NOTE: Cover plate is installed, properly torqued, and sealed in the factory prior to shipment.

 **WARNING**

Ensure cover plate is firmly attached. Do not lift anything other than the dampener with the two lifting lugs or material failure may occur.

5. Lift the dampener, turn it over, or lay it on its side to gain access to the bottom threaded mounting holes.

6. Insert the flange mounting studs into the 8 threaded holes in the bottom of the PD unit.

NOTE: All studs should be seated to ensure that they are properly inserted. There should be less than 0.25' (6 mm) variation in installed height.

7. Lower the dampener onto the mating flange and API ring.

8. Once seated, ensure the gap between the mounting flange and dampener bottom connection is equal around the circumference.

9. Install the nuts onto the mounting studs and tighten using an alternating crisscross pattern to the proper torque as listed below.

NOTE: Torque values are for Performance Pulsation Control's Xylan® coated studs and nuts. If using a lubricant, consult lubricant supplier or contact PPC for new torque values.

| Unit | Bolt Size | UNC | Lubricated Torque | |
|------------|-----------|-----|-------------------|------|
| | | | in | mm |
| PD05-5000 | 1.375 | 35 | 600 | 813 |
| PD05-7500 | 1.625 | 41 | 900 | 1220 |
| PD05-10000 | 1.625 | 41 | 900 | 1220 |
| PD05-15000 | 2.5 | 63 | 1500 | 2034 |
| PD10-5000 | 1.625 | 41 | 930 | 686 |
| PD10-7500 | 2 | 51 | 1100 | 1491 |
| PD20-1440 | 1 | 24 | 400 | 543 |
| PD20-5000 | 1.875 | 35 | 1500 | 2033 |
| PD20-7500 | 2.25 | 57 | 1500 | 2033 |

Special Note: For PD units equipped with a 1-1/4"-7NC socket head cap screw, the torque for that fastener is 1175ft. lbs.

MATERIALS NEEDED:

- Pure Nitrogen Gas – At greater pressure than desired pre-charge pressure
- Regulator – Must accommodate desired pre-charge pressure
- Charging Hose Kit
- General Hand Tools



WARNING

Always pre-charge with NITROGEN! Verify that Nitrogen bottles contain pure nitrogen gas. There have been documented reports of both end users and service providers using bottles containing all or up to 30% oxygen to charge their diaphragms/bladders. Those incidents led to catastrophic dampener explosions. This type of incident represents a potential loss of life.

The dampener must be isolated from the system (0 PSIG) and fluid drained before pre-charging.

INTRODUCTION:

PPC recommends using a reputable nitrogen gas supplier that can provide written bottle filling procedures and verification for nitrogen gas purity. PPC further recommends that each bottle be clearly marked with an appropriate Compressed Nitrogen Gas Association shoulder label. All nitrogen gas bottles should come with a 580 - type valve unless you are using a bottle with a greater than 3000 psig pressure rating, which should have a 680 - type valve installed.

One of the most important factors in proper pulsation dampener performance is establishing the correct pre-charge pressure. Normally, the pre-charge pressure is based on charging the dampener up to 75% of the minimum system operating pressure, to a maximum of 2500 psig (172.4 bar). As a general rule, the pre-charge ratio (pre-charge pressure / operating pressure) should fall between 25% and 75% at system operating conditions. Operating the dampener with a pre-charge ratio outside of this range will have potentially negative effects on the diaphragm service life.

Pre-charging the diaphragm is accomplished by using commercially available nitrogen cylinders. The number of nitrogen cylinders required to pre-charge the diaphragm will depend on dampener capacity and pre-charge pressure. The chart that follows is based on the use of STD 224 cubic feet, 2200 PSI dry nitrogen cylinders.

| Cylinders Required | | |
|--------------------|---------------------|------------------------|
| Unit | Pre-charge Pressure | No. Cylinders Required |
| PD05 Series | 0 - 1400 | 1 |
| | 1400 - 1600 | 2 |
| | 1600 - 2200 | 3 |
| PD10 Series | 0 - 900 | 1 |
| | 900 - 1500 | 2 |
| | 1500 - 2500 | 3 |
| PD20 Series | 0 - 770 | 1 |
| | 770 - 1300 | 2 |
| | 1300 - 2500 | 3 |

CHARGING INSTRUCTIONS:

1. Remove the valve cover by locating and removing the two 1/2" bolts located on the valve cover.
2. Ensure that all cover plate nuts are secured and evenly tightened according to the torque table below.

| Unit | Bolt Size | UNC | Lubricated Torque | |
|------------|-----------|-----|-------------------|------|
| | | | ft-lb | nm |
| PD05-5000 | 1.375 | 35 | 600 | 813 |
| PD05-7500 | 1.625 | 41 | 900 | 1220 |
| PD05-10000 | 1.625 | 41 | 900 | 1220 |
| PD05-15000 | 2.5 | 63 | 1500 | 2034 |
| PD10-5000 | 1.625 | 41 | 930 | 686 |
| PD10-7500 | 2 | 51 | 1100 | 1491 |
| PD20-1440 | 1 | 24 | 400 | 543 |
| PD20-5000 | 1.875 | 35 | 1500 | 2033 |
| PD20-7500 | 2.25 | 57 | 1500 | 2033 |

Special Note: For PD units equipped with a 1-1/4"-7NC socket head cap screw, the torque for that fastener is 1175ft. lbs.

3. Turn the charging valve clockwise until it stops to ensure full closure; do not over-tighten.
4. Remove the protective cap from charging valve.
5. Install the regulator onto nitrogen source.
6. Connect the charging hose assembly to the charging valve and the regulator on the nitrogen cylinder.
7. Set the regulator to 0-psi.
8. Open the charging valve by turning the 5/8" safety nut three full turns counter-clockwise.
9. Check the pre-charge pressure in dampener with charging kit gauge.
NOTE: *Charging hose gauge and dampener gauge should read the same pressure.*
10. Slowly open the nitrogen cylinder valve. With the regulator set to 0-psi there should be little or no flow in the charging hose line.
11. Slowly adjust the regulator to allow nitrogen to flow until the recommended pre-charge pressure shows on the regulator gauge.
12. Allow the pressure in the dampener to build to the proper pre-charge pressure.
13. Close the charging valve by turning the safety nut fully clockwise until it stops and is snug.
NOTE: *Failure to properly close the charging valve will result in nitrogen leaking out of the diaphragm and result in poor performance and early diaphragm failure.*
14. Close the nitrogen cylinder valve and reduce the pressure regulator to 0-psi to ensure no additional gas comes out of the cylinder tank.
NOTE: *Additional cylinders may be required to bring the dampener to proper pressure. If additional cylinders are required, repeat steps #5 through #14 until the desired pressure is obtained.*
- NOTE:** *When the pre-charge is complete, the regulator pressure, the charging hose pressure, and dampener pressure gauge should read the same. Dampener gauge must read the same as other gauges. If not, replace dampener gauge.*
15. Slowly bleed the pressure from the charging hose by slightly loosening the cylinder connection nut until the charging hose pressure gauge reads zero. This should be done with caution. Release all pressure in the line before fully removing the connection.
16. Apply soapy water or similar leak detection fluid around the fittings, connections, studs, and flange mating areas. Bubbles forming in the applied water indicates a leak. If a leak is detected, re-tighten the connections and check again. Reinstallation of the gauge or charging valve in the dampener may be required to stop a leak.
17. Remove the charging hose assembly and reinstall the charging valve protective cap.
18. Confirm the pre-charge pressure on the dampener pressure gauge.
19. Reinstall the valve cover and securely tighten the 1/2" bolts to 56 ft-lbs of torque. Your pulsation dampener is now ready for operation.

GENERAL INSPECTION

1. Regularly observe the dampener pressure gauge and ensure it is properly functioning. During pump operations it should display a similar pressure as the pump's discharge pressure gauge. If it reads differently or no pressure at all, then the dampener gauge needs to be replaced.
2. Inspect the pre-charge pressure on the dampener monthly, or anytime the system is showing excess vibrations.
NOTE: *Pre-charge pressure should be checked only when the system pressure is at 0-psi.*
3. During pre-charge inspection, check the unit for loose nuts, random debris, possible leaks, damage, corrosion, and overall general condition.
4. Tighten any loose fasteners, clear debris, and correct leaks. Note the cause of and seek to correct any corrosion or other damage. If damage is severe, contact PPC for a safety evaluation.

MATERIALS NEEDED:

- Socket Wrench
- TFE Tape
- Emery Cloth
- General Hand Tools

DIAPHRAGM REPLACEMENT**WARNING**

Verify that your Nitrogen bottles contain pure nitrogen (N²) gas. There have been documented reports of both end users and service providers using bottles containing all or up to 30% oxygen to charge their diaphragms/bladders. These incidents led to catastrophic dampener explosions. This type of incident represents a potential loss of life!

1. Isolate the pulsation dampener from the pumping system. Ensure that the system pressure reads 0-psi.
2. Remove the valve cover to gain access to the charging valve. Keep hardware for reuse. Remove the protective cap from the charging valve. Turn the 5/8" safety nut fully counter-clockwise to ensure there is no pre-charge pressure left on the system. Confirm the pressure is 0-psi on the pressure gauge.
3. Attach properly rated lifting shackles and lifting device to the lift lugs on cover plate.
4. Loosen the cover plate nuts using a crisscross pattern and back the nuts away from the cover surface. Do not completely remove the nuts at this time.

**WARNING**

Do not remove the nuts completely until the cover plate has been lifted and it has been proven there is no longer a pre-charge on the system. Reuse of removed diaphragm is not recommended.

5. Using a hoist, slowly and partially lift the cover plate with the provided lifting lug shackles until the rubber diaphragm seal has been broken and releases any possible remaining nitrogen gas.
6. Remove the cover plate nuts and remove the cover plate.
7. Reach into the bottom of the bladder and remove the existing stabilizer bolt, lock washer, stabilizer plate, and stabilizer.
8. Install a lifting eye into the 1"-8NC hole at the bottom of the diaphragm and remove the existing diaphragm.
9. Inspect the interior of the vessel for burrs, debris or excess pitting. Mild scale or pitting may be removed with the application of a light emery cloth. If excessive pitting, corrosion or wear is found, contact a Performance Pulsation Control representative. If corrosion or wear is found during inspection, all other pulsation dampeners should also be inspected. Flush the shell before the new diaphragm is reinstalled.
10. Inspect the dampener bore and diaphragm sealing areas for burrs, nicks, or discontinuities that could prevent sealing. Repair as necessary using an emery cloth.
11. Inspect new diaphragm (refer to parts for proper diaphragm material) for any damage. Ensure the new diaphragm is intact and free of any discontinuities.
12. Coat the bore area and the diaphragm with a light coat of grease to aid in installation.
13. Pull up on the neck of the diaphragm while pushing the steel insert at the bottom down, elongating the diaphragm.
14. Roll the sides of the diaphragm to form a football shape, using a strap to hold it in this position.

15. Insert the folded diaphragm length-wise into the dampener and open it up inside the body of the vessel.
16. Adjust the neck of the diaphragm to fit uniformly over the gasket surface of the dampener bore.
17. Install the diaphragm stabilizer, stabilizer plate, lock washer and bolt. Tighten the bolt securely using a socket wrench.

| |
|---|
|  CAUTION |
| Installation of the cover plate is the reverse of removal. Exercise care when lowering the cover plate to ensure that the diaphragm is not crushed or folded over on the diaphragm sealing surface. |

18. Hand-tighten the nuts onto each stud. Then tighten in a standard crisscross pattern until tightened to the required torque level.

| Unit | Bolt Size | UNC | Lubricated Torque | |
|------------|-----------|-----|-------------------|------|
| | in | mm | ft-lb | nm |
| PD05-5000 | 1.375 | 35 | 600 | 813 |
| PD05-7500 | 1.625 | 41 | 900 | 1220 |
| PD05-10000 | 1.625 | 41 | 900 | 1220 |
| PD05-15000 | 2.5 | 63 | 1500 | 2034 |
| PD10-5000 | 1.625 | 41 | 930 | 686 |
| PD10-7500 | 2 | 51 | 1100 | 1491 |
| PD20-1440 | 1 | 24 | 400 | 543 |
| PD20-5000 | 1.875 | 35 | 1500 | 2033 |
| PD20-7500 | 2.25 | 57 | 1500 | 2033 |

Special Note: For PD units equipped with a 1-1/4"-7NC socket head cap screw, the torque for that fastener is 1175ft. lbs.

19. Pre-charge the dampener in accordance with the charging instructions found previously in this manual and check for leaks.

MATERIALS NEEDED:

- General Hand Tools
- TFE Tape

INTRODUCTION

Prior to performing any service on the pulsation dampener, determine if the dampener pressure is properly functioning. A faulty gauge must be replaced. Failure to verify gauge is properly functioning can lead to poor performance, premature diaphragm failure, and possibly damage or injury.

Gauge and charging valve are provided with a repair kit order. See Appendix for repair kit info. When replacing gauge, ensure TFE tape is applied in the correct direction of each part's male thread to protect threads and to ensure complete sealing. Proper direction is such that the TFE tape doesn't unwind when threading these parts into the cover plate.

1. Isolate the pulsation dampener from the pumping system. Ensure that the system pressure reads 0-psi.
2. Bleed off the nitrogen pressure within the dampener to 0-psi.
3. Prepare the new gauge by wrapping the threads with TFE tape. Wrap the tape in such a way and direction to ensure that the TFE will not unwind when being installed.
4. Remove the existing gauge.
5. Thread the new gauge into the pulsation cover and tighten properly.
6. Attach the warranty tag.
7. If the charging valve is not being replaced, pre-charge the dampener in accordance with the charging instructions found previously in this manual and check for leaks.
8. If replacing the charging valve, loosen the safety nut and remove the existing valve.
9. Prepare the new valve by wrapping the threads with TFE tape. Wrap the tape in such a way and direction to ensure that the TFE will not unwind when being installed.
10. Install the new valve and ensure the safety nut has been tightened properly.
11. Pre-charge the dampener in accordance with the charging instructions found previously in this manual and check for leaks.

Appendix



All Gas Charged Pulsation Control Equipment is designed to Section VIII Division I of the ASME Pressure Vessel Code. Specific certifications are available and are shown below.

| PD05 MODELS | | | |
|---|--|--|--|
| Model 5 gallon = 18.9 liters | Description <i>Other certifications such as ABS, DNV, NR13 available PED with CE stamp & GOST available at an extra charge.</i> | Assembly Part Number | |
| | | NBR (Nitrile Bladder) Continuous 0°F-212°F (-18°C-100°C) Intermittent 250°F (121°C) | HNBR (Hydrogenated Nitrile Bladder) Continuous 0°F-250°F (-18°C-121°C) Intermittent 300°F (149°C) |
| PD05-5000 5000 psi = 344.7 bar | 5 Gallon 5000 psi - ASME | PD0550-01011-ASME | PD0550-07011-ASME |
| PD05-7500 7500 psi = 517.1 bar | 5 Gallon 7500 psi - ASME | PD0575-01011-ASME | PD0575-07011-ASME |
| PD05-10000 10000 psi = 689.5 bar | 5 Gallon 10000 psi - ASME | PD0510-01011-ASME | PD0510-07011-ASME |
| PD05-15000 15000 psi = 1034.2 bar | 5 Gallon 15000 psi - ASME | PD0515-01011-ASME | PD0515-07011-ASME |

| PD10 MODELS | | | | |
|--|--|---|--|---|
| Model 10 gallon = 38 liters | Description <i>Other certifications such as ABS, DNV, NR13 available PED with CE stamp & GOST available at an extra charge.</i> | Assembly Part Number | | |
| | | NBR Continuous 0°F-212°F (-18°C-100°C) Intermittent 250°F (121°C) | HNBR Continuous 0°F-250°F (-18°C-121°C) Intermittent 300°F (149°C) | URETHANE Continuous 0°F-180°F (-18°C-82°C) Intermittent 220°F (104°C) |
| PD10-5000 5000 psi = 345 bar | 10 Gallon 5000 psi - ASME | PD1050-01011 | PD1050-07011 | PD1050-09011 |
| PD10-7500 7500 psi = 659.5 bar | 10 Gallon 7500 psi - ABS-CDS | PD01075-01011-ABS | PD1075-07011-ABS | PD1075-09011-ABS |

| PD20 MODELS | | | | |
|--|--|---|--|---|
| Model 20 gallon = 76 liters | Description <i>Other certifications such as ABS, DNV, NR13 available PED with CE stamp & GOST available at an extra charge.</i> | Assembly Part Number | | |
| | | NBR Continuous 0°F-212°F (-18°C-100°C) Intermittent 250°F (121°C) | HNBR Continuous 0°F-250°F (-18°C-121°C) Intermittent 300°F (149°C) | URETHANE Continuous 0°F-180°F (-18°C-82°C) Intermittent 220°F (104°C) |
| PD20-1440 1400 psi = 99 bar | 20 Gallon 1440 psi - ASME | PD201440-01011 | PD201440-0711 | PD201440-09011 |
| PD20-5000 5000 psi = 345 bar | 20 Gallon 5000 psi - ASME | PD2050-01011 | PD2050-07011 | PD2050-09011 |
| PD20-7500 7500 psi = 517 bar | 20 Gallon 7500 psi - ABS-CDS | PD02075-01111-ABS | PD2075-07111-ABS | PD2075-09111-ABS |

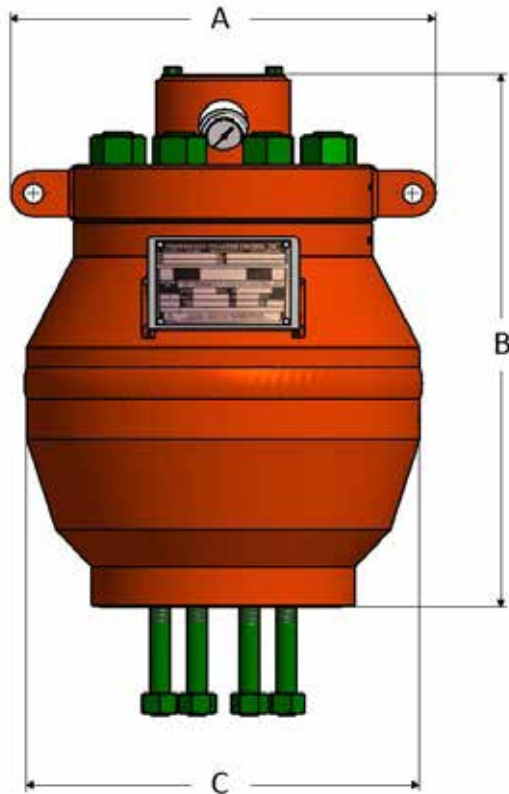

| | | | |
|-----------|--------|---------|----------|
| PD05-5000 | A | 18.69" | 474.7 mm |
| | B | 23.0" | 584.2 mm |
| | C | 12.25" | 311.2 mm |
| | Weight | 600 lbs | 272 kg |

| | | | |
|-----------|--------|---------|------------|
| PD05-7500 | A | 20-3/8" | 517.525 mm |
| | B | 24-1/8" | 612.775 mm |
| | C | 18-1/4" | 463.55 mm |
| | Weight | 705 lbs | 320 kg |

| | | | |
|------------|--------|---------|------------|
| PD05-10000 | A | 21-318" | 536.575 mm |
| | B | 26-1/2" | 673.100 mm |
| | C | 19-1/2" | 495.300 mm |
| | Weight | 919 lbs | 4170 kg |

| | | | |
|------------|--------|----------|--------|
| PD05-15000 | A | 24-3/4" | 704 mm |
| | B | 29-1/4" | 743 mm |
| | C | 21-3/4" | 552 mm |
| | Weight | 1420 lbs | 644 kg |

| | | | |
|-----------|--------|----------|----------|
| PD10-5000 | A | 24" | 612.8 mm |
| | B | 28-9/16" | 725.4 mm |
| | C | 23" | 584.2 mm |
| | Weight | 1917 lbs | 870 kg |

| | | | |
|-----------|--------|----------|----------|
| PD10-7500 | A | 24-1/8" | 612.8 mm |
| | B | 28-7/8" | 733.5 mm |
| | C | 23-1/8" | 587.4 mm |
| | Weight | 1917 lbs | 870 kg |

| | | | |
|-----------|--------|----------|---------|
| PD20-1440 | A | 21-1/2" | 546 mm |
| | B | 28-7/8" | 733 mm |
| | C | 24-1/4" | 616 mm |
| | Weight | 682 lbs. | 309 kg. |

| | | | |
|-----------|--------|-----------|----------|
| PD20-5000 | A | 27-3/8" | 695.4mm |
| | B | 33-5/8" | 854.1 mm |
| | C | 27-1/8" | 689 mm |
| | Weight | 1851 lbs. | 840 kg. |

| | | | |
|-----------|--------|-----------|----------|
| PD20-7500 | A | 30-1/2" | 774.7 mm |
| | B | 35-7/8" | 911.2 mm |
| | C | 29-1/8" | 739.8 mm |
| | Weight | 2759 lbs. | 1252 kg |

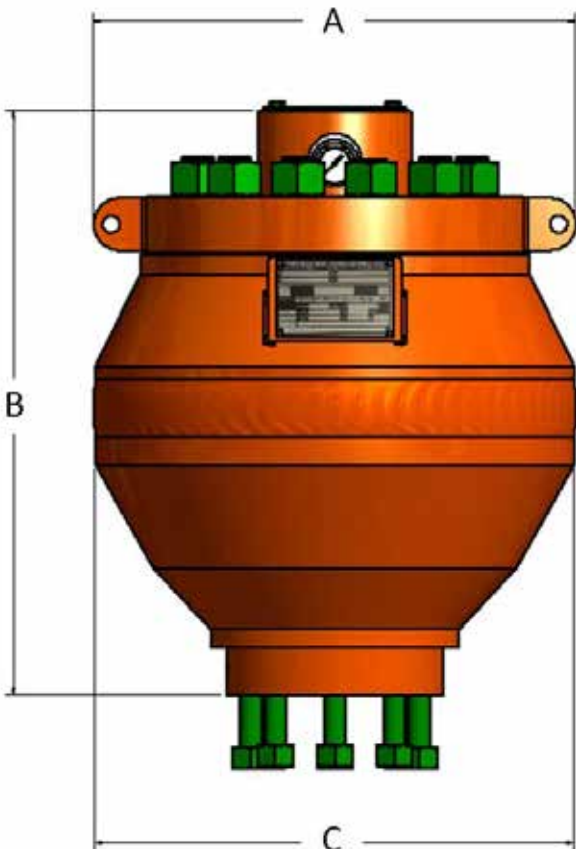

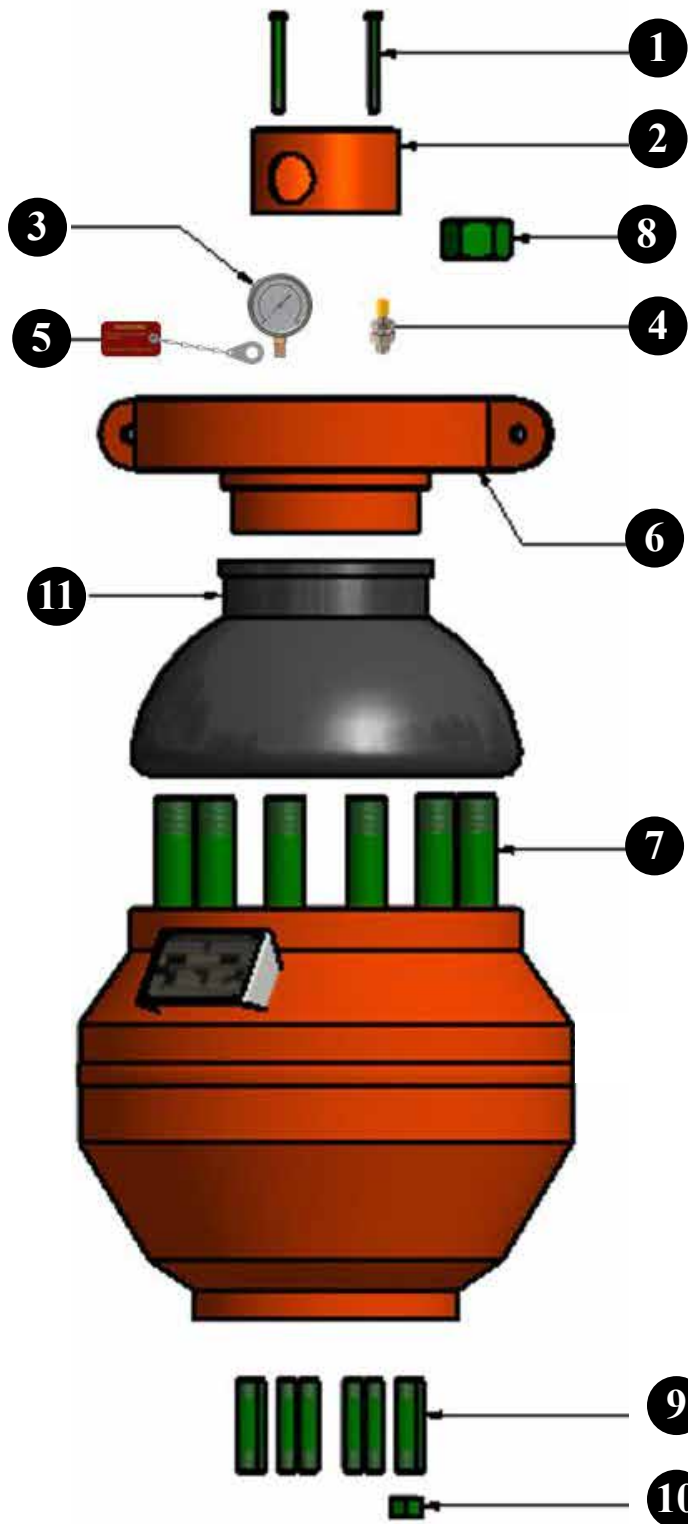

| PD05 CONNECTION SIZING | PD05-5000 | PD05-7500 | PD05-10000 | PD05-15000 |
|------------------------|---------------|-----------------|-----------------|-----------------|
| Connection | 3-1/8" API 5k | 2-9/16" API 10k | 2-9/16" API 10k | 2-9/16" API 15k |
| Ring Gasket | R35 | BX153 | BX153 | BX153 |

| # | DESCRIPTION | PD05 PART NUMBERS | | | |
|----|--|-----------------------------|-----------------------------|-----------------------------|-----------------------------|
| | | PD05-5000 | PD05-7500 | PD05-10000 | PD05-15000 |
| 1 | VALVE COVER BOLT | PD05-VCB | PD05-VCB | PD05-VCB | PD05150-VCB |
| 2 | VALVE COVER | PD05-VC | PD05-VC | PD05-VC | PD05150-VC |
| 3 | PRESSURE GAUGE | PD0550-PG | PD05-PG | PD05100-PG | PD05150-PG |
| 4 | LOADING VALVE | PD0550-LV | PD0575-LV | PD05100-LV | PD05150-LV |
| 5 | WARNING TAG | PDWTAG1 | PDWTAG1 | PDWTAG1 | PDWTAG1 |
| 6 | COVER PLATE | PD0550-CP | PD0575-CP | PD05100-CP | PD05150-CP |
| 7 | COVER PLATE STUD (8 Req.) | PD0550-CPS | PD0575-CPS | PD05100-CPS | PD05150-CPS |
| 8 | COVER PLATE NUT (8 Req.) | PD0550-CPN | PD0575-CPN | PD05100-CPN | PD05150-CPN |
| 9 | CONNECTION STUD (8 Req.- shipped loose) | PD0550-BPST | PD0575-BPST | PD05100-BPST | PD05150-BPST |
| 10 | CONNECTION NUT (8 Req.- shipped loose)) | PD0550-BPN | PD0575-BPN | PD05100-BPN | PD05150-BPN |
| 11 | DIAPHRAGM | PD05-01 NBR PD05-07 HNBR | PD05-01 NBR PD05-07 HNBR | PD05-01 NBR PD05-07 HNBR | PD05-01 NBR PD05-07 HNBR |

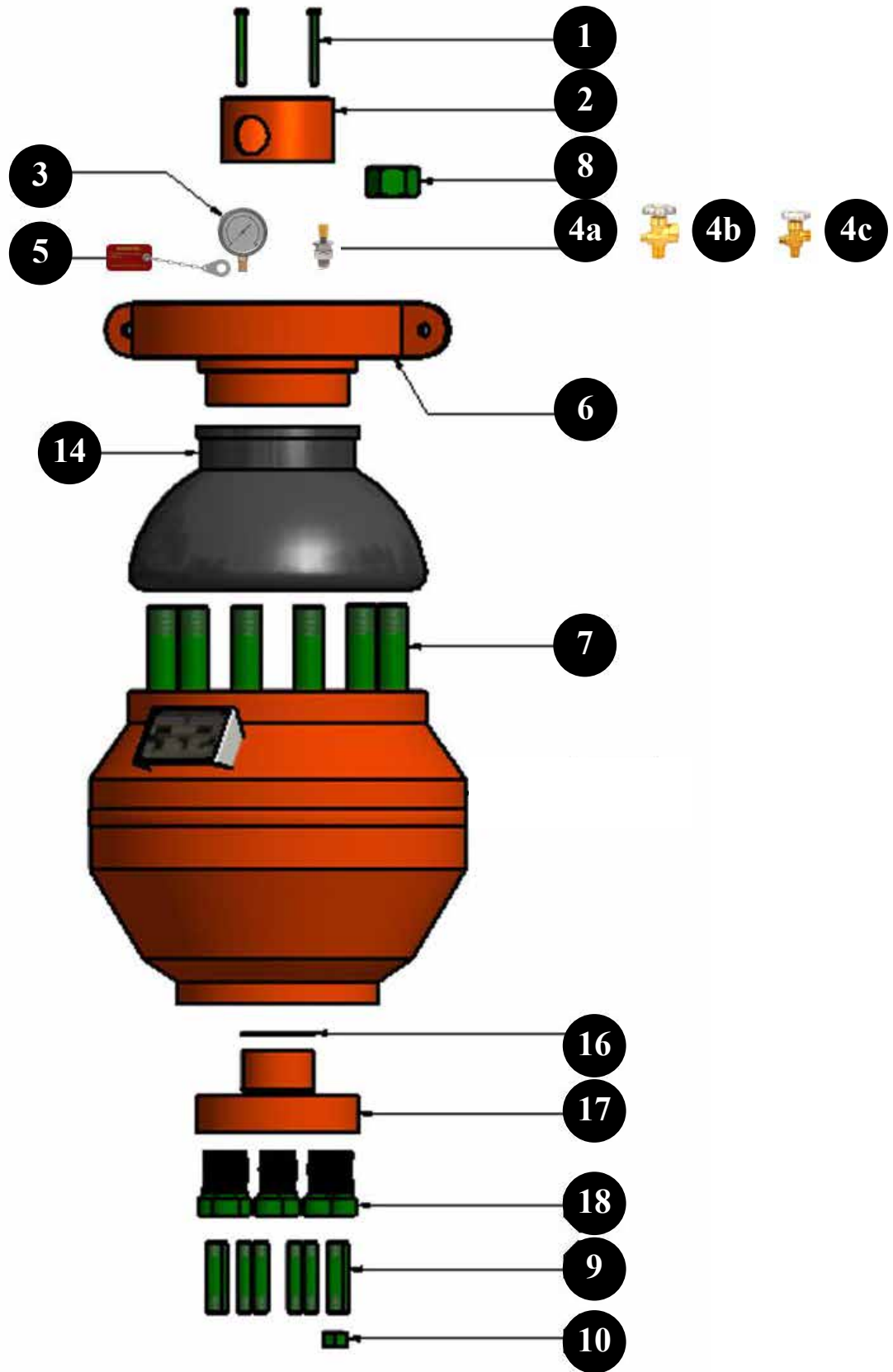

| PD10 CONNECTION SIZING | PD10-5000 | PD10-7500 | |
|------------------------|---------------------|-----------------|-----------------|
| Connection | 4 1/6" API 5K | 4 1/16" API 10K | |
| Ring Gasket | R39 | BX155 | |
| PD20 CONNECTION SIZING | PD20-1440 | PD20-5000 | PD20-7500 |
| Connection | 4" ASME Class 600 | 4 1/16" API 5K | 4 1/16" API 10K |
| Ring Gasket | Spiral Wound Gasket | R39 | BX155 |

| ITEM | DESCRIPTION | PD 10 PART NUMBERS | | PD20 PART NUMBERS | | |
|------|-------------------------------------|--|--|--|--|--|
| | | PD10-5000 | PD10-7500 | PD20-1440 | PD20-5000 | PD20-7500 |
| 1 | VALVE COVER BOLT | PD10-VCB | PD10-VCB | PD20-VCB | PD20-VCB | PD20-VCB |
| 2 | VALVE COVER | PD10-VC | PD10-VC | PD20-VC | PD20-VC | PD20-VC |
| 3 | PRESSURE GAUGE | PD1050-PG | PD1075-PG | PD2075-PG | PD2050-PG | PD2075-PG |
| 4a | LOADING VALVE (Schrader) | PD1050-LV | PD1075-LV | PD2075-LV | PD2050-LV | PD2075-LV |
| 4b | LOADING VALVE (CGA680) | | | VLV_CGA680_SHERWOOD | VLV_CGA680_SHERWOOD | |
| 4c | LOADING VALVE (CGA677) | | | | | VLV_CGA677_SHERWOOD |
| 5 | WARNING TAG | PDWTAG1 | PDWTAG1 | PDWTAG1 | PDWTAG1 | PDWTAG1 |
| 6 | COVER PLATE with lift lugs | PD1050-CP | PD1075-CP | PD201440-CP | PD2050-CP | PD2075-CP |
| 7 | COVER PLATE STUD (12 Req.) | PD1050-CPS | PD1075-CPS | PD201440-CPS | PD2050-CPS | PD2075-CPS |
| 8 | COVER PLATE NUT (12 Req.) | PD1050-CPN | PD1075-CPN | PD201440-CPN | PD2050-CPN | PD2075-CPN |
| 9 | ADAPTER PLATE SEAL | PD10-BPS | PD10-BPS | PD201440-BPS | PD20-BPS | PD20-BPS |
| 10 | ADAPTER PLATE | PD1050-BP | PD1075BP | PD201440-BP | PD2050-BP | PD2075-BP |
| 11 | ADAPTER PLATE CAPSCREW (8 Req.) | PD1050-BPCS | PD1075-BPCS | PD201440-BPCS | PD2050-BPCS | PD2075-BPCS |
| 12 | CONNECTION STUD (8 Req.) | PD1050-BPST | PD1075-BPST | PD201440-BPST | PD2050-BPST | PD2075-BPST |
| 13 | CONNECTION NUT (8 Req. -ship loose) | PD1050-BPN | PD1075-BPN | PD201440-BPN | PD2050-BPN | PD2075-BPN |
| 14 | DIAPHRAGM | NBR P/N: PD10-01 HNBR P/N: PD10-07 URETHANE P/N: PD10-09 | NBR P/N: PD10-01 HNBR P/N: PD10-07 URETHANE P/N: PD10-09 | NBR P/N: PD20-01 HNBR P/N: PD20-07 URETHANE P/N: PD20-09 | NBR P/N: PD20-01 HNBR P/N: PD20-07 URETHANE P/N: PD20-09 | NBR P/N: PD20-01 HNBR P/N: PD20-07 URETHANE P/N: PD20-09 |
| 15 | NBR STABILIZER | PD10-ST-01 | PD10-ST-01 | PD20-ST-01 | PD20-ST-01 | PD20-ST-01 |
| 16 | STABILIZER PLATE | PD10-ST-PLT | PD10-ST-PLT | PD20-ST-PLT | PD20-ST-PLT | PD20-ST-PLT |

| # | DESCRIPTION | PD05 PART NUMBERS | | | |
|----|-----------------------|-----------------------------|-----------------------------|-----------------------------|-----------------------------|
| | | PD05-5000 | PD05-7500 | PD05-10000 | PD05-15000 |
| 11 | DIAPHRAGM | PD05-01 NBR PD05-07 HNBR | PD05-01 NBR PD05-07 HNBR | PD05-01 NBR PD05-07 HNBR | PD05-01 NBR PD05-07 HNBR |
| 12 | NBR STABILIZER | PD05-ST-01 | PD05-ST-01 | PD05-ST-01 | PD05-ST-01 |
| 13 | STABILIZER PLATE | PD05-ST-PLT | PD05-ST-PLT | PD05-ST-PLT | PD05-ST-PLT |
| 14 | STABILIZER LOCKWASHER | PD05-ST-LW | PD05-ST-LW | PD05-ST-LW | PD05-ST-LW |
| 15 | STABILIZER BOLT | PD05-ST-BLT | PD05-ST-BLT | PD05-ST-BLT | PD05-ST-BLT |

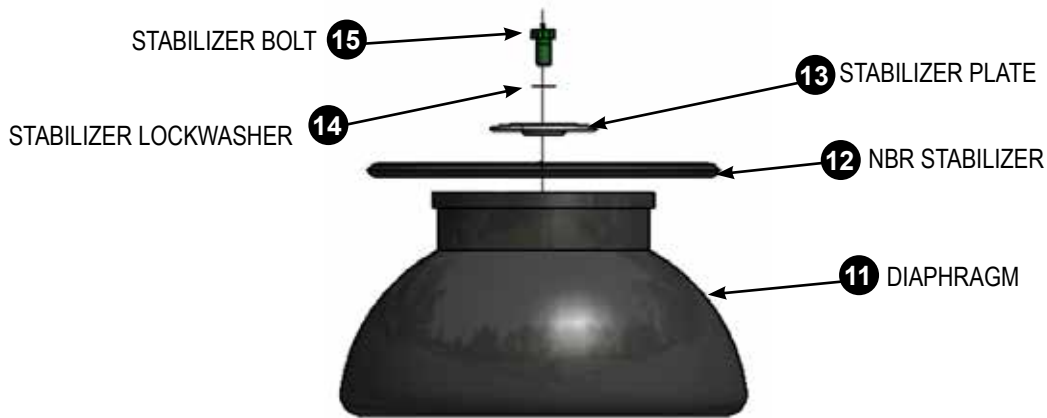

| DESCRIPTION | PD05 DIAPHRAGM KIT PART NUMBERS | | | |
|--|---------------------------------|--------------------------|--------------------------|-------------------------------|
| | PD05-5000 | PD05-7500 | PD05-10000 | PD05-15000 |
| Kit Includes #11-15: Diaphragm, NBR Stabilizer, Stabilizer Plate, Stabilizer Lockwasher, Stabilizer Bolt | PD05-01-DK PD05-07-DK | PD05-01-DK PD05-07-DK | PD05-01-DK PD05-07-DK | PD0515-01- DK PD0515-07-DK |



3 PRESSURE GAUGE



4 Charging valve



5 WARNING TAG



9 CONNECTION STUDS

| DESCRIPTION | REPAIR KIT NUMBERS | | | |
|--|------------------------------|------------------------------|-----------------------------|------------------------------|
| | PD05-5000 | PD05-7500 | PD05-10000 | PD05-15000 |
| Kit Includes #3,4,5 & 9: Pressure Gauge, Loading Valve, Warning Tag, Connection Stud | PD0550-01-RK PD0550-07-RK | PD0575-01-RK PD0575-07-RK | PD0510-01-R PD0510-07-RK | PD0515-01-RK PD0515-07-RK |

| # | DESCRIPTION | PART NUMBERS | | | | |
|----|-----------------------|---|---|-----------------------------|-----------------------------|-----------------------------|
| | | PD10-5000 | PD10-7500 | PD20-1440 | PD20-5000 | PD20-7500 |
| 14 | DIAPHRAGM | PD10-01 NBR PD10-07 HNBR PD10-09 URETHANE | PD10-01 NBR PD10-07 HNBR PD10-09 URETHANE | PD20-01 NBR PD20-07 HNBR | PD20-01 NBR PD20-07 HNBR | PD20-01 NBR PD20-07 HNBR |
| 15 | NBR STABILIZER | PD10-ST-01 | PD10-ST-01 | PD20-ST-01 | PD20-ST-01 | PD20-ST-01 |
| 16 | STABILIZER PLATE | PD10-ST-PLT | PD10-ST-PLT | PD20-ST-PLT | PD20-ST-PLT | PD20-ST-PLT |
| 17 | STABILIZER LOCKWASHER | PD10-ST-LW | PD10-ST-LW | PD20-ST-LW | PD20-ST-LW | PD20-ST-LW |
| 18 | STABILIZER BOLT | PD10-ST-BLT | PD10-ST-BLT | PD20-ST-BLT | PD20-ST-BLT | PD20-ST-BLT |

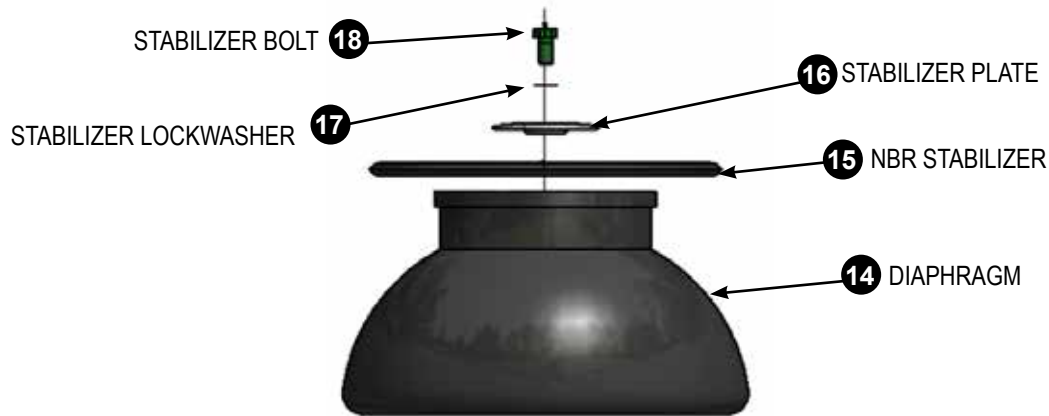

| DESCRIPTION | DIAPHRAGM KIT PART NUMBERS | | | | |
|--|----------------------------|--------------------------|--------------------------|--------------------------|--------------------------|
| | PD10-5000 | PD10-7500 | PD20-1440 | PD20-5000 | PD20-7500 |
| Kit Includes #14-18: Diaphragm, NBR Stabilizer, Stabilizer Plate, Stabilizer Lockwasher, Stabilizer Bolt | PD10-01-DK PD10-07-DK | PD10-01-DK PD10-07-DK | PD20-01-DK PD20-07-DK | PD20-01-DK PD20-07-DK | PD20-01-DK PD20-07-DK |



3 PRESSURE GAUGE



4b LOADING VALVE



5 WARNING TAG



9 CONNECTION STUDS

| DESCRIPTION | REPAIR KIT NUMBERS | | | | |
|---|------------------------------|------------------------------|------------------------------|-----------------------------|-----------------------------|
| | PD10-5000 | PD10-7500 | PD20-1440 | PD20-5000 | PD20-7500 |
| Kit Includes #3,4,5 & 12: Pressure Gauge, Loading Valve, Warning Tag, Connection Stud | PD1050-01-RK PD1050-07-RK | PD1075-01-RK PD1075-07-RK | PD201440-01-R PD201440-RK | PD2050-01-R PD2050-07-RK | PD2075-01-R PD2075-07-RK |